

Three-Phase DC-AC Inverter With Low Power Dissipation Filter For Photovoltaic-Based Micro-Grid Scale Electric Power System

Vinsensius Letsoin
Dept. Electrical Engineering
University of Musamus
Merauke, Indonesia
letsoinvins@yahoo.co.id

Faizal Arya Samman
Dept. Electrical Engineering
Universitas Hasanuddin
Makassar, Indonesia
faizalas@unhas.ac.id

A. Ejah Umraeni Salam
Dept. Electrical Engineering
Universitas Hasanuddin
Makassar, Indonesia
ejahsalam@gmail.com

Abstract—This paper presents a three-phase DC-AC inverter with a low power dissipation filter for photovoltaic-based micro-grid power system. The traditional LCL and LLCL filters can reduce harmonic disruptions, but they create new problems in terms of a considerable resonance in their fundamental frequency. They also results in lower power output. Therefore, this paper proposes a new filter configuration that can improve power output but does not increase the THD. A comparative study of several filter topologies, including the LCL, LLCL filters and the new filter, is presented in this paper. The simulation results show that the new proposed filter with a H-bridge damper element gives THD of about 0.39% for the output voltage and about 1.98% for output current. The average output voltage amplitude of the filter is about 220V-380V, which is almost similar to its input voltage domain. With those input voltage domain, the proposed filter can deliver about 6.8-7.1kW output power with very impressive power efficiency of about 95%. (*Abstract*)

Keywords—Power Electronics, 3-Phase Inverter, Power Passive Filter, Passive Damping Method

I. INTRODUCTION

Recent years, the increases of population and technological development demand more electric power supplies in large numbers. All sectors of industries, transportation, offices, households and others need more reliable electric energy in the future. Meanwhile, the availability of fossil energy supplies is nowadays limited [1] and the price offered each year also rises. Therefore, renewable energies are considered as the best alternative energy sources. Solar cells convert solar radiation emission, as one of unlimited energy sources, into electrical energy. This energy source is one of the promising renewable energies in the future.

Fig. 1 shows a solar-based power generation system. The solar-based power generation system uses an inverter (voltage source converter) to be able to supply electrical power to the load. The inverter output voltage form can be guided using a pulse width modulation (PWM) signal or a sinusoidal pulse width modulation (SPWM) signal. The problem of VSC control using the PWM or SPWM is the total harmonics distortion (THD). To overcome this problem, a power passive filter (PPF) is then used. PPF is one part of a grid-connected voltage converter source that has been used as the backbone of most renewable energy systems over the past decade [2].

Therefore, we propose a new solution to design PPF that can improve power efficiency and THD. Passive filter design is a fairly complicated task [3], even if the circuit is simpler.

PPF is also able to keep the integration and connection between the grid and inverter without transformer.

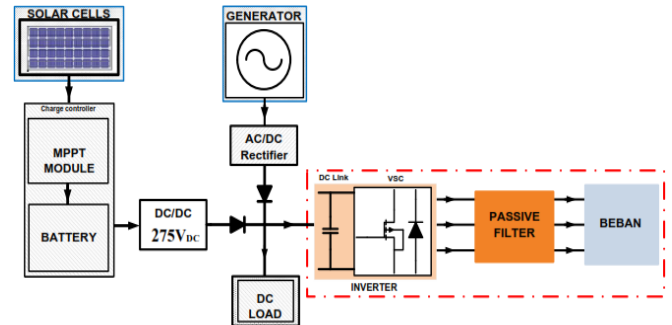

Fig. 1. Diagram of a hybrid grid and solar-based power generation system with DC power source coupling.

In passive filter design, it is necessary to consider the design procedure of power converter to be used. There are several PPF topologies that are often proposed in literature, i.e. Single-Tuned LLC and LLCL [3, 4]. Single-Tuned LCL and LLCL filters as simple filters have very small fundamental frequency losses. Both filters will be compared with our proposed H-bridge damper filter. The proposed filter can reduce harmonics and improve the power quality and efficiency. The power efficiency delivered by the PPF has decreased. A number of studies have introduced some new inventions, but almost all paper do not expose the PPF by considering the load contribution to the PPF performances. The PPF concepts can reduce harmonic interference under the IEEE standard [5] but a new problem appears, in terms of resonance to the fundamental frequency response, which results in decreased power efficiency. Naturally, the load is sure a part of filter and thus it can affect the power quality and efficiency.

Our proposed filter is called H-bridge damper filter. The performance of the proposed H-bridge damper filter is compared to other popular filters. The performance analysis involves the existence of loads as part of filters. The load types that are connected to filter output are R, R+L, R+C, and R+L+C. The criteria used to analyze are resonance damping figures in form of a frequency response diagram, THD, output voltage amplitudes, power efficiency, and output power.

The remaining sections in this paper are organized as follows. Section II discusses the design of system models. Section III shows the simulation results. Section IV presents the comparative study presented in quantitative values in some tables. Finally, the work is concluded in Section V.

II. SYSTEM DESIGN AND MODELING

A. Three-Phase Inverter Model

The inverter and filter are designed, modeled and simulated using SPICE Program [6]. Signal generators and analysis components are also modeled in the SPICE program. In this design, we will present five passive damping methods showing their frequency response, THD, output power, Voltage amplitude, and power efficiency as the basis for filter analysis [7]. The circuit schematic with full bridge configuration of the three-phase inverter is shown in Fig. 2.

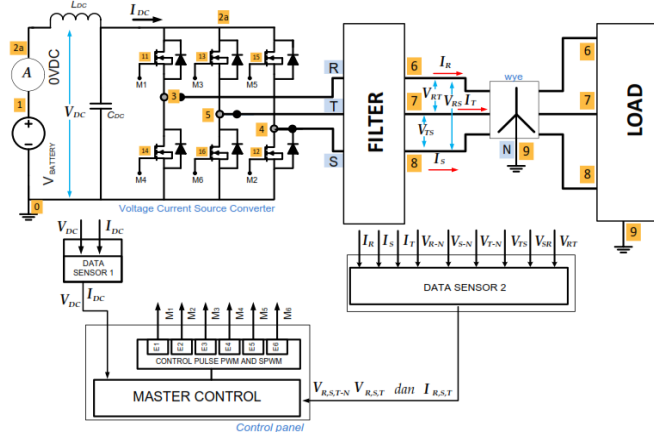

Fig. 2. Inverter system models.

$M_1, M_2, M_3, M_4, M_5,$ and M_6 as respective switching devices MOSFET. Diodes $D_1, D_2, D_3, D_4, D_5,$ and D_6 are protection elements for the MOSFET, respectively. The 3-phase inverter generates filtered output voltages $V_R, V_S,$ and V_T . The PPF output current are $I_R, I_S, I_T, E_1, E_2, E_3, E_4, E_5,$ and E_6 are power-driven PWM switching control signals.

Modulated signals are applied to the gate terminals of the MOSFET with a certain period to maintain the desired frequency of 50~Hz [8].

B. Selected Load Types for Analysis

Fig. 3 presents 4 types of load configurations, namely resistance load, resistance+capacitance (RC) load, resistance +inductive (RL) load, and resistance+inductance +capacitance (RLC) load. Certainly, there are many unlimited load configurations. However, we select only four types, which are commonly used in practical applications.

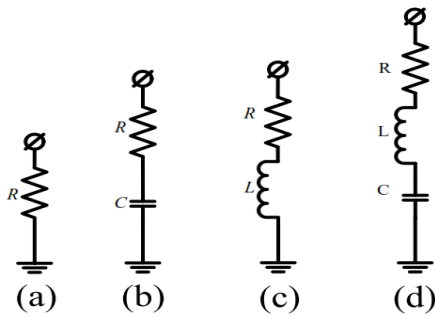

Fig. 3. Installed load model (a). R, (b). RL, (c). RC, and (d). RLC (parameters $R=220\text{ohm}, L=10\text{mH},$ and $C=3.3\mu\text{F}$)

C. Selected Filter Topology for Comparative Study

There are several filter models used in various applications with different harmonic traps, size, design cost and characteristics. The choice of passive filter topology used for filter resonance conditions is based on a separate passive shunt filter dampers for many security systems are applied [9]. In this paper, we will analyze the PPF outputs when its output terminal is connected to any type of filters. Fig. 4. shows the selected filter topology, which are briefly explained as follows.

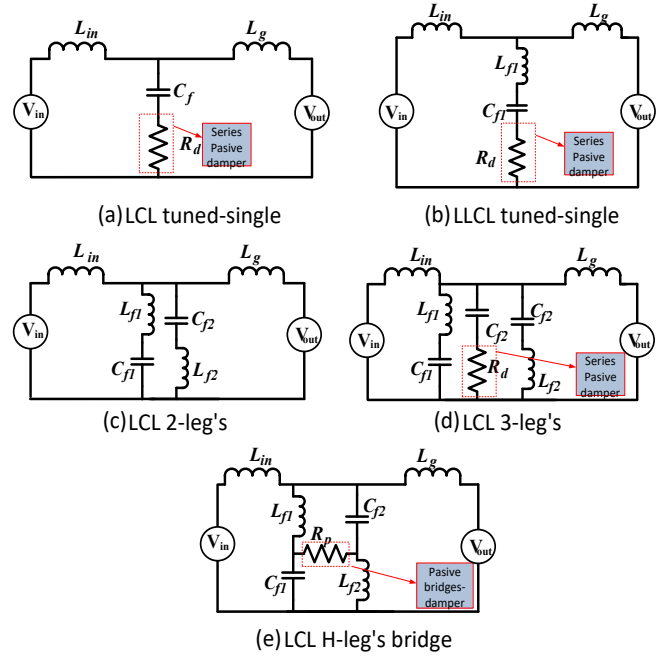

Fig. 4. The proposed filter schematics (a) single-tuned LCL, (b) single-tuned LLCL, (c) LCL 2-leg, (d) LCL 3-leg (e) LCL H-bridge damper.

- 1) LCL single-tuned filter or LCL filter + (series) damper resistance.

This passive filter is very simple, the resistors are mounted in series along with the capacitors in the design. The series resistor along with the capacitor serves as a channel with a slightly big impedance and is effective in harmonic reduction, but has fundamental frequency losses.

- 2) LLCL single-tuned filter or LLCL + (series) damper resistance.

It offers simple series harmonics attenuation capabilities at frequencies having peak resonance or fundamental losses. The resistor should be carefully selected to resume the harmonics reductions and good voltage amplitude.

- 3) LCL filter with 2 LC legs or multi-tuned trap filter [11]

The filter serves to reduce current loss. Therefore, two equal combinations (LC-LC legs) without resistors is presented. Although this filter has no impedance resistors, it can produce good performance on harmonic reduction. But it has a frequency-loss which is difficult to mediate. It also has a high resonance, but when resonance is encumbered it can be overcome.

- 4) LCL 3-leg filter or LCL multi-tuned trap filter with extra damper in series with C-leg. [11].

As completion of 2-leg LCL filter, a combination of series resistor-capacitor is added between the two previous traps. Hence, it has a pretty good performance rather than the LCL single-tuned, LLCL single-tuned filter and LCL 2-leg filter.

- 5) LCL Filter + H-bridge damper as the completion of the 2-leg's LCL filter, a resistor is inserted to make a bridge between two LC legs. This is our proposed filter that will be examined together with the aforementioned filters in the next section.

III. SIMULATION RESULTS

This section presents some simulation results, i.e. frequency response and time domain transient simulations. The parameters used in the simulations are shown in Table. I. The first simulation result presented in this section is the effectiveness of the inverter using the PWM or SPWM switching control signals.

Table. I. Parameters of the simulation

Input Voltage	275V				
Output Voltage	220V-380V				
Frequency	50Hz				
Output Power	3kW s/d 7kW				
Var./Param.	LCL+R	LLCL+R	LCL 2-leg's	LCL 3-leg's	LCL bridge
Lin	10 mH	10 mH	10 mH	10 mH	10 mH
Lg	4.7 mH	4.7 mH	4.7 mH	4.7 mH	4.7 mH
Lf1	-	1 mH	3 mH	3 mH	3 mH
Lf2	-	3 mH	3 mH	3 mH	0.11 uF
Cf1	470 uF	4.7 uF	0.11 uF	0.11 uF	0.11 uF
Cf2	-	-	0.11 uF	0.11 uF	0.11 uF
R	8 Ohm	80 Ohm	-	31 Ohm	20 Ohm

A. Selected Switching Control Signal for Analysis

Two switching control signals, i.e. PWM or SPWM can be applied. This section analyzes the THD and output voltage amplitude when using one of both switching signals. Fig. 5 shows the time domain output voltage simulation results using both switching signals. It seems that they produce different phase-phase and phase-neutral phase amplitudes. Table. II shows the results of the comparison between the two switching control signals. It seems that in the inverter with PWM control signal gives better phase-to-phase and phase-to-neutral characteristics, in terms of THD values and output voltage amplifications. Further simulation and analysis presented in this paper use inverter model with the PWM signal. The inverter with SPWM is not discussed accordingly in this paper.

B. Frequency Response Characteristics of the Filters

Fig. 6 presents the frequency response curves of the compared filters. It seems that all of them are categorized into low-pass filter type. The LCL 2-leg filter gives the worst damping characteristic. While, the LLCL 3-leg and LLCL H-bridge damper present the best damping characteristics.

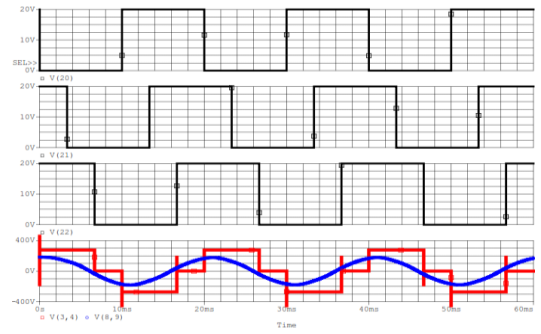

a). PWM switching control method

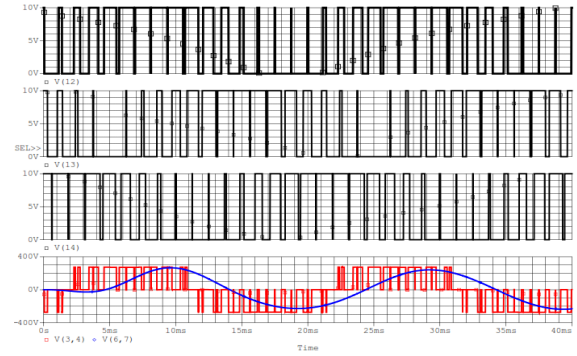

b). SPWM switching control method

Fig. 5. Transient simulation of the PWM and SPWM switching control methods.

Table. II. Simulation results from each PWM and SPWM control without passive filter.

Line	PWM		SPWM	
	Vout	THD	Vout	THD
R-T	387	30.5	296	63.1
S-R	387	30.5	295	63.1
T-S	387	30.5	295	63.3
R-N	221	30.5	171	95.3
S-N	221	30.5	170	95.2
T-N	221	30.5	170	95.2

C. Time Domain Output Voltage Simulation

Fig. 7 shows the output waveform of the output voltages for each filter. The average time spot of stable amplitudes is at 0.03~ms and 0.04~ms. Each filter provides a variable amplitudes, and all filters have different output amplitudes. To measure the amplitude of the sine voltage, it is necessary to consider the impedance value at the inverter and filter output terminal.

D. Time Domain Output Power Simulation

Fig. 8 shows the simulation results for the output power of the compared five filters. As shown in the figure, it seems that the the LCL 2-leg and LCL H-bridge damper filter provide almost equal average power performance. The LLCL filter+damper resistor gives the worst average output power values.

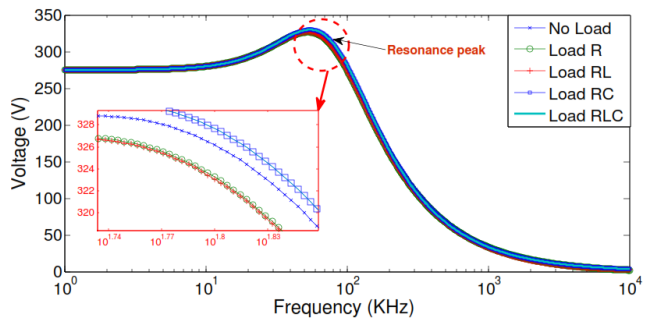

(a). LCL+damper

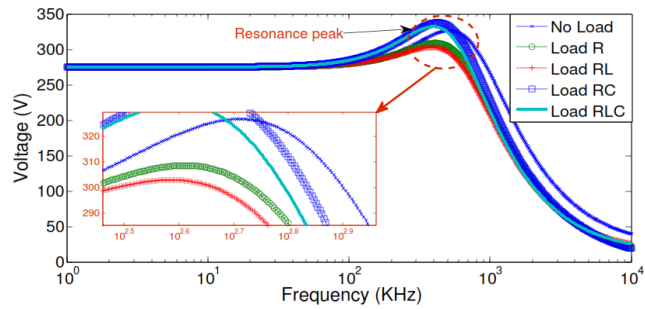

(b). LLCL+damper

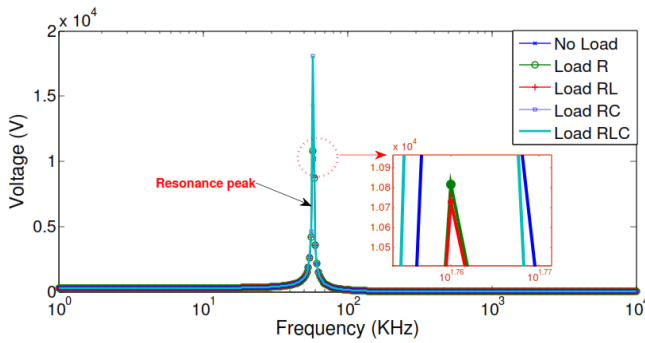

(c). LCL 2-leg

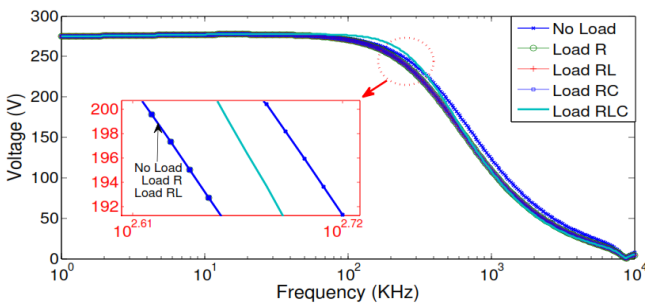

(d). LCL 3-leg

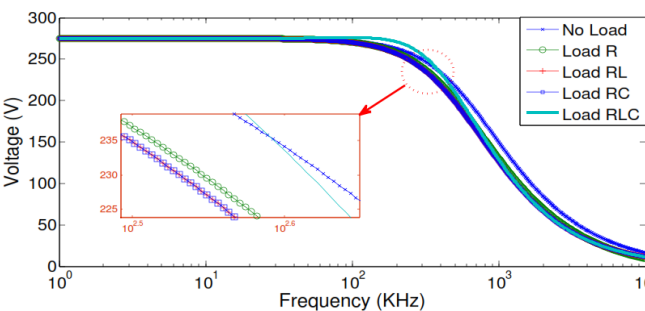

(e). LCL H-bridge damper

Fig. 6. The frequency response curves of the filters.

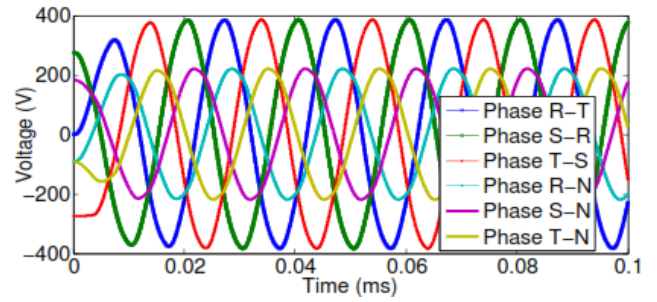

(a). LLCL+damper

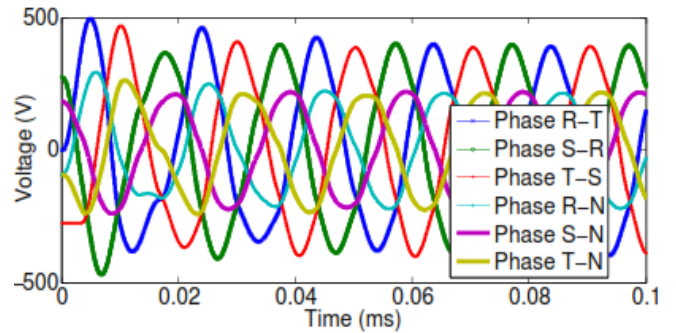

(b). LLCL+damper

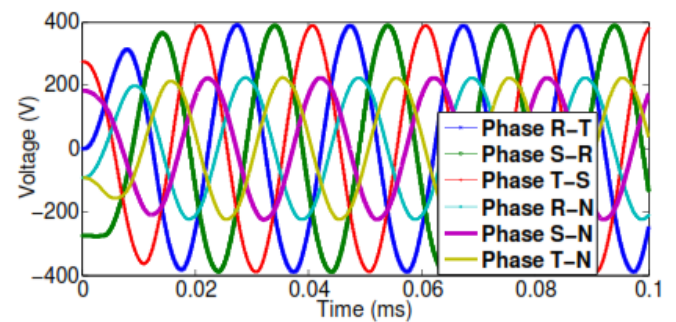

(c). LCL 2-leg

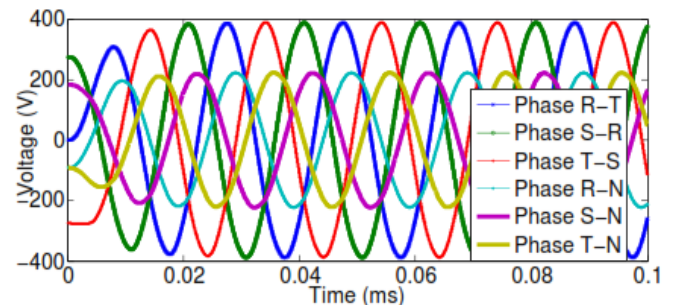

(d). LCL 3-leg

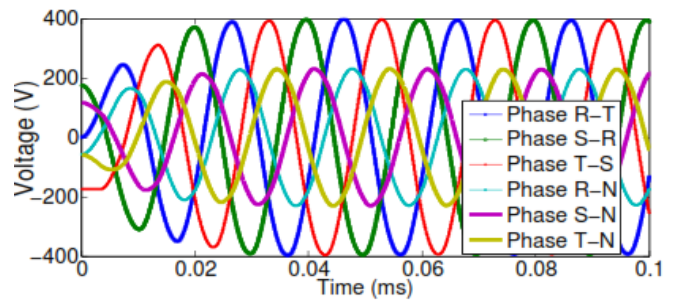

(e). LCL H-bridge damper

Fig. 7. Output voltage waveform.

E. Time Domain Output Power Simulation

Fig. 9 shows the simulation results for the output power of the compared five filters. As shown in the figure, it seems that the the LCL 2-leg and LCL H-bridge damper filter provide almost equal average power performance. The LLCL filter+damper resistor gives the worst average output power values.

IV. THE THD AND POWER EFFICIENCY ANALYSIS

A. Measurement and Comparative Statistics

This section presents the quantitative data of the simulation results presented in the previous section. The supplied voltage is 380v and 220V on average. Table. III presents the quantitative data of the simulation without load. It seems that the LCL H-bridge damper filter provides the best THD attenuation performance for the output voltage. The LCL 2-leg filter gives the THD reduction for the output current. Power efficiency of the LCL H-bridge damper filter is also better than the other filters.

Table. III. The simulation data without load.

Filter	THD (V)	THD (A)	Ouput Power (kW)	(Vout)	Effic. (P)
LCL+Rd	1.18%	1.18%	9.6	221-380	50%
LLCL+Rd	3.47%	3.47%	4.7	225-390	11%
LCL 2-leg	0.51%	0.51%	1.4	222-389	78%
LCL 3-leg	0.53%	0.53%	1.3	222-387	66%
LCL Bridge	0.33%	1.98%	7.1	223-384	95%

In the previous table, the filter is not connected to any load. Load is naturally a part of the filter itself, and can affect the inverter output performances. Table. IV presents the comparative data when each filter is connected to a resistance load. We can see that the filter LCL H-bridge damper gives the best THD attenuation, followed by the LCL 2-leg, LCL 3-leg, LCL+damper resistor (R_d) and the LLCL+damper resistor. The best performance in term of power efficiency is presented again by the LCL H-bridge damper. The result is principally almost similar to the previous simulation result without load.

Table. IV. The simulation result data with load R.

Filter	THD (V)	THD (A)	Ouput Power (kW)	(Vout)	Effic. (P)
LCL+Rd	1.18%	1.18%	9.6	217-380	61%
LLCL+Rd	3.40%	3.40%	5.1	225-389	11%
LCL 2-leg	0.50%	0.50%	1.4	219-381	66%
LCL 3-leg	0.53%	0.53%	1.2	217-380	78%
LCL Bridge	0.39%	1.98%	6.9	214-369	95%

Table. IV shows the comparison result when each filter is connected to the R+L load. The performance data present almost similar result with the previous table.

Table. V. The simulation result data with load RL.

Filter	THD (V)	THD (A)	Ouput Power (kW)	(Vout)	Effic. (P)
LCL+Rd	1.18%	1.18%	9.6	217-380	61%
LLCL+Rd	3.40%	3.40%	5.1	225-389	11%
LCL 2-leg	0.50%	0.50%	1.4	219-381	78%
LCL 3-leg	0.53%	0.53%	1.1	217-380	66%
LCL Bridge	0.39%	1.98%	6.8	214-368	95%

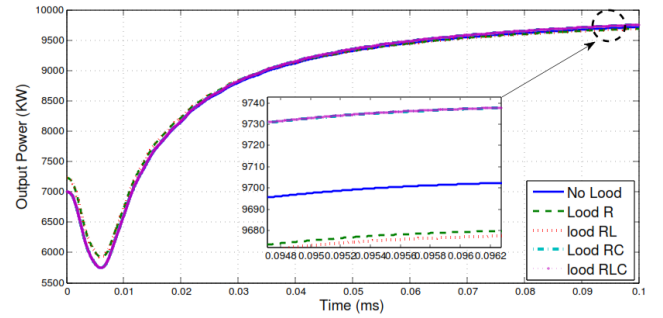

(a). LCL+damper

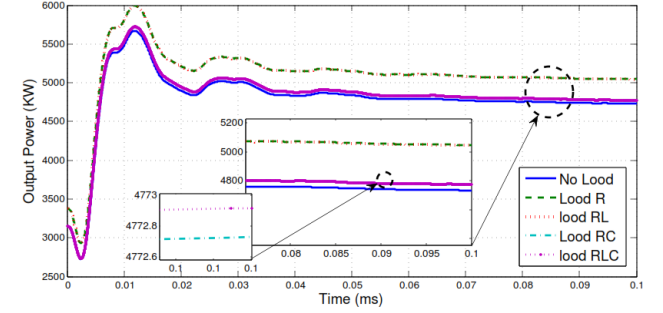

(b). LLCL+damper

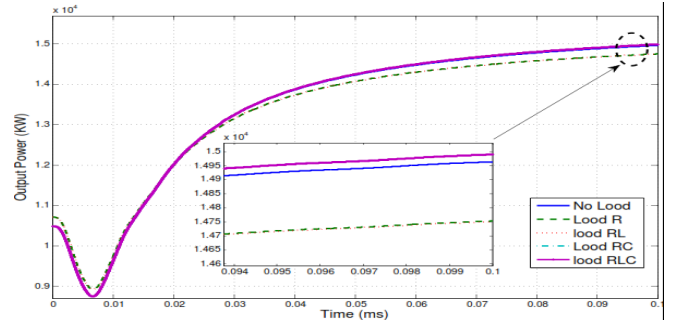

(c). LCL 2-leg

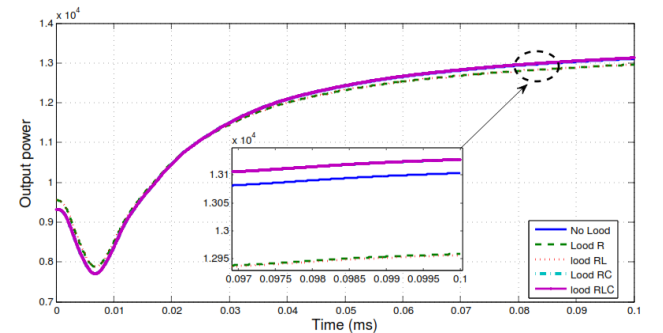

(d). LCL 3-leg

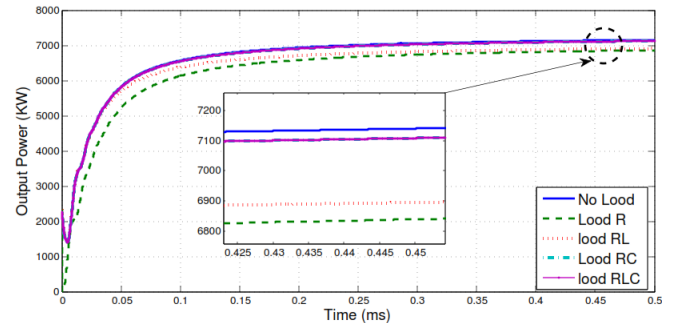

(e). LCL H-bridge damper

Fig. 8. Time domain output power simulations.

Table. V shows the comparison result when each filter is connected to the R+C load.

Table. VI. The simulation result data with load RC

Filter	THD (V)	THD (A)	Ouput Power (kW)	(Vout)	Effic. (P)
LCL+Rd	1.18%	1.18%	9.6	221-380	50%
LLCL+Rd	3.40%	3.40%	5.1	225-392	11%
LCL 2-leg	0.50%	0.50%	1.4	223-389	78%
LCL 3-leg	0.53%	0.53%	1.3	222-387	66%
LCL Bridge	0.39%	1.98%	7.1	222-382	95%

Table. VII shows the comparison result when each filter is connected to the R+L+C load. The performance data present almost similar result with the previous table.

Table. VII. The simulation result data with load RLC

Filter	THD (V)	THD (A)	Ouput Power (kW)	(Vout)	Effic. (P)
LCL+Rd	1.18%	1.18%	9.7	221-387	49%
LLCL+Rd	3.49%	3.60%	7.9	225-392	11%
LCL 2-leg	0.50%	0.50%	1.4	223-389	78%
LCL 3-leg	0.53%	0.53%	1.3	222-387	66%
LCL Bridge	0.39%	1.98%	7.1	222-382	95%

V. CONCLUSIONS

This paper has presented a novel low power dissipation power filter for three-phase DC-AC inverters used in PV-based home scale or micro-grid scale power system generation. The novel passive filter is called as the LCL plus H-bridge-damper filter. The damping resistor is located in the filter to bridge two L-C legs in the filter, and is used to damp the resonance effect of the filter.

From the comparative study with SPICE simulation, the LCL H-bridge damper filter outperforms the other existing LCL and LLCL type filters. The THD reduction of the output voltage of the LCL H-bridge damper is also better than the other filters, i.e. about 0.39% for the certain selected load parameter values. The load configuration does not affect significantly the THD attention, both for output voltage and the output current. However, THD reduction of its output current is not better than the LCL 2-leg and LCL 3-leg filters. Principally, all filters can give acceptable THD attenuation according to IEEE standard, i.e. below 5%.

The most interesting performance figure of the LCL H-bridge damper filter is its power efficiency, which is about 95% with output power about 6.8kW until 7.1kW for the certain selected load parameter values. Therefore, based on the simulation results, the passive filter with LCL plus H-bridge damper element becomes a promising passive power filter for PV-based power inverter circuit. In the future, we will realized the filter hardware, test the system circuits, and compare the testing results with the simulation results.

ACKNOWLEDGMENT

The authors gratefully acknowledge the Ministry of Research, Technology and Higher Education of the Republic of Indonesia (by *Direktorat Riset & Pengabdian Masyarakat – DRPM*) for funding our research under the scheme of "Post-Graduate Collegium Research Grant" (*Hibah Penelitian Tim Pasca Sarjana*) in the year 2017 and 2018.

REFERENCES

- [1] M. H. Mahlooji, H. R. Mohammadi, and M. Rahimi, "A review on modeling and control of grid-connected photovoltaic inverters with lcl filter," *Renewable and Sustainable Energy Reviews*, vol. 81, pp. 563–578, 2018.
- [2] M. Huang, X. Wang, P. C. Loh, and F. Blaabjerg, "Lcl-filtered grid converter with improved stability and robustness," *IEEE Trans. On Power Electronics*, vol. 31, no. 5, pp. 3958–3967, 2015.
- [3] IEEE, IEEE Standard for Metal-Oxide Surge Arresters for AC Power Circuits (above 1 kV). IEEE-SA Standards Board, Surge Protective Devices Committee of the IEEE Power Engineering Society, 1999.
- [4] M. Alali and J. Barbot, "A first order sliding mode controller for grid connected shunt active filter with a lcl filter," *IFAC–Papers On Line*, vol. 50, no. 1, pp. 14 812 – 14 817, 2017, 20th IFAC World Congress.
- [5] M. M. Alam, H. Leite, N. Silva, and A. da Silva Carvalho, "Performance evaluation of distance protection of transmission lines connected with vsc-hvdc system using closed-loop test in rtds," *Electric Power Systems Research*, vol. 152, pp. 168–183, 2017.
- [6] B. Okur, E. Zergeroglu, M. Seker, and E. Tatcioglu, "Nonlinear robust control of 3 phase inverter with output lc filter," *IFAC Proceedings Volumes*, vol. 47, no. 3, pp. 529 – 533, 2014, 19th IFAC World Congress.
- [7] M. H. Rashid and H. M. Rashid, *SPICE for Power Electronics and Electric Power*. Taylor & Francis Group, 2006.
- [8] F. A. Samman, M. Hasan, and T. Damayanti, "Design and analysis of dc/ac inverter using passive lcl filter with damping circuit configuration," in *Proc. of the 2017 Int'l Seminar on Intelligent Technology and Its Applications (ISITIA)*, 2017.
- [9] F. A. Samman and A. Azhari, "Dc/ac power converter for home scale electricity systems powered by renewable energy," in *Proc. of the 2016 Int'l Conf. on Smart Green Technology in Electrical and Information Systems (ICSGTEIS)*, 2016, pp. 149–154.
- [10] N.-C. Yang and M.-D. Le, "Optimal design of passive power filters based on multi-objective bat algorithm and pareto front," *Applied Soft Computing*, vol. 35, pp. 257–266, 2015.
- [11] M. Buyuk, A. Tan, M. Tumay, and K. C. Bayindir, "Topologies, generalized designs, passive and active damping methods of switching ripple filters for voltage source inverter: A comprehensive review," *Renewable and Sustainable Energy Reviews*, vol. 62, pp. 46 – 69, 2016